

The CU Aerospace (CUA) Fiber-fed Pulsed Plasma Thruster (FPPT) self-contained system uses PTFE fiber as propellant. This approach enables CUA to provide competitive  $\Delta V$  to CubeSat and small satellite customers at a substantially lower cost and risk profile than traditional liquid or gaseous propulsion systems that use valves and pressurized tank feed systems. In a 1.7U form factor, FPPT can provide a peak total impulse of 24,000 N-s, a peak continuous thrust of 0.50 mN at 96 W input power, and a maximum specific impulse of 3,200 seconds. The design incorporates a modularized 32 J energy storage unit (ESU) to achieve a balance between performance and propellant volume. Steady operation at 0.5Hz has been demonstrated with 3Hz capability in shorter duration burns. The FPPT has a unique gimbal-less thrust vectoring capability allowing reaction wheel desaturation and attitude control outside Earth’s magnetic field. Presently, an FPPT flight unit is being qualified for launch on CUA’s NASA-funded Dual Propulsion Experiment (“DUPLEX”) 6U CubeSat mission in mid-2023. Thrust vectoring of  $\pm 10^\circ$  in the pitch and yaw axes has been measured on a laboratory FPPT system and will be demonstrated on the DUPLEX mission.



### OPERATION AND TYPICAL PERFORMANCE

FPPT fires on demand without warmup. It mechanically feeds PTFE propellant fiber from a non-rotating spool through the anode, utilizing a pulsed discharge to electromagnetically accelerate fuel to provide thrust. Power, thrust, mass flow rate, and resultant specific impulse levels are user-selectable by adjusting propellant feed rate, pulse rate, and bank voltage.

System Information	
System Lifetime	> 10 <sup>8</sup> pulses
System Temperature Range [°C]	- 40 to +75
Nominal Pulse Energy [J]	32
Propulsion System Volume	1.7U
Pulse Rate [Hz]	0.5   3
Nominal Power to PPU [W]	16   96
Nominal Mass Flow Rate [mg/s]	0.00265   0.0158
Nominal Thrust [mN]	0.085   0.50
Minimum Impulse Bit [ $\mu$ N-s]	165
Specific Impulse [s]	3,200
Total Impulse [N-s]	24,000
Propellant Mass [kg]	0.78
Total propulsion wet mass [kg]	3.03
Spacecraft $\Delta V$ , M(initial)=10.5 kg [m/s]	2,420
TRL	6

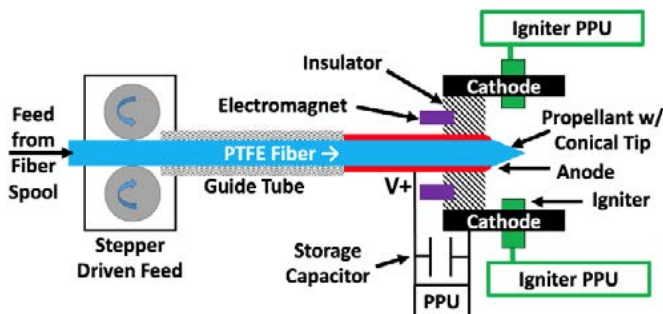

**BASELINE 1.7U FPPT SYSTEM INTERFACE**

- 12V power interface (can modify on request)
- RS422 or TTL level RS232 communication protocols available
- Mounting interface
  - Designed for typical CubeSat structure with external enclosure
  - Adaptable to customer requirements
- 21.7 x 9.0 x 8.65 cm<sup>3</sup> envelope
- Total mass of 3.03 kg

